

AVANTE

AS8 ACTIVE LINE ARRAY
PA SYSTEM

ELEVATING
YOUR
SOUND

USER
MANUAL

 МУЗЦЕНТР
МУЗЫКАЛЬНОЕ ОБОРУДОВАНИЕ

<https://muzcentre.ru>

©2019 ADJ PRODUCTS LLC all rights reserved. Information, specifications, diagrams, images, and instructions herein are subject to change without notice. ADJ logo and identifying product names and numbers herein are trademarks of ADJ PRODUCTS LLC. Copyright protection claimed includes all forms and matters of copyrightable materials and information now allowed by statutory or judicial law or hereinafter granted. Product names used in this document may be trademarks or registered trademarks of their respective companies and are hereby acknowledged. All non-ADJ brands and product names are trademarks or registered trademarks of their respective companies.

ADJ PRODUCTS LLC and all affiliated companies hereby disclaim any and all liabilities for property, equipment, building, and electrical damages, injuries to any persons, and direct or indirect economic loss associated with the use or reliance of any information contained within this document, and/or as a result of the improper, unsafe, insufficient and negligent assembly, installation, rigging, and operation of this product.

AVANTE World Headquarters USA

6122 S. Eastern Ave. | Los Angeles, CA 90040 USA
323-316-9722 | Fax: 323-582-2941 | www.avanteaudio.com | info@avanteaudio.com

AVANTE NETHERLANDS

Junostraat 2 | 6468 EW Kerkrade | Netherlands
+31 45 546 85 00 | Fax: +31 45 546 85 99 | europa@avanteaudio.com

AVANTE MEXICO

Santa Ana 30 | Parque Industrial Lerma | Lerma Mexico 52000
+52 (728) 282.7070 | ventas@avanteaudio.com

FCC STATEMENT

This device complies with Part 15 of the FCC Rules. Operation is subject to the following two conditions: (1) this device may not cause harmful interference, and (2) this device must accept any interference received, including interference that may cause undesired operation.

FCC RADIO FREQUENCY INTERFERENCE WARNINGS & INSTRUCTIONS

This product has been tested and found to comply with the limits as per Part 15 of the FCC Rules. These limits are designed to provide reasonable protection against harmful interference in a residential installation. This device uses and can radiate radio frequency energy and, if not installed and used in accordance with the included instructions, may cause harmful interference to radio communications. However, there is no guarantee that interference will not occur in a particular installation. If this device does cause harmful interference to radio or television reception, which can be determined by turning the device off and on, the user is encouraged to try to correct the interference by one or more of the following methods:

- Reorient or relocate the device.
- Increase the separation between the device and the receiver.
- Connect the device to an electrical outlet on a circuit different from which the radio receiver is connected.
- Consult the dealer or an experienced radio/TV technician for help.

Energy Saving Matters (EuP 2009/125/EC)

Saving electric energy is a key to help protecting the environment. Please turn off all electrical products when they are not in use. To avoid power consumption in idle mode, disconnect all electrical equipment from power when not in use. Thank you!

Document Version: An updated version of this document may be available online. Please check www.avante.com for the latest revision/update of this document before beginning installation and use.

The Bluetooth® word mark and logos are registered trademarks owned by Bluetooth SIG, Inc. and any use of such marks by Avante Audio is under license. Other trademarks and trade names are those of their respective owners.

Date	Document Version	Notes
02/28/19	1	Initial release
03/13/19	2.1	Updated manual format
03/14/19	2.2	Fixed typos
03/22/19	2.3	Updated factory information

CONTENTS

General Information	4
Limited Warranty (USA Only)	5
Safety Guidelines	6
Maintenance Guidelines	8
Overview	9
Setup	11
Connections & Controls	12
Installation	15
Frequency Charts	16
Troubleshooting	17
Technical Specifications	18
Optional Components	18

GENERAL INFORMATION

INTRODUCTION

This speaker is designed for professional use only. Please read and understand all the instructions and guidelines in this manual carefully and thoroughly before attempting to operate these speakers. These instructions contain important information regarding safety, installation, and use.

UNPACKING

Every speaker has been thoroughly tested and has been shipped in perfect operating condition. Carefully check the shipping carton for damage that may have occurred during shipping. If the carton appears to be damaged, carefully inspect speaker for damage and be sure all accessories necessary to install and operate the speaker have arrived intact. In the event damage has been found or parts are missing, please contact our customer support team for further instructions. Please do not return this speaker to your dealer without first contacting customer support at the number listed below. Please do not discard the shipping carton in the trash. Please recycle whenever possible.

CUSTOMER SUPPORT

AVANTE provides a customer support line to provide set up help, answer any question should you encounter problems during your set up or initial operation, and for any service related issues.

You may also visit us on the web at www.avanteaudio.com for any comments or suggestions.

AVANTE SERVICE USA – Monday – Friday 8:00am to 4:30pm PST

Voice: 800-322-6337

Fax: 323-532-2941

support@avanteaudio.com

AVANTE SERVICE EUROPE - Monday - Friday 08:30 to 17:00 CET

Voice: +31 45 546 85 30

Fax: +31 45 546 85 96

europe@avanteaudio.com



@avanteaudio

WARRANTY REGISTRATION

Please register your product online: www.avanteaudio.com Online product registration is required in order to activate the third year of the 3-year warranty. All returned service items, whether under warranty or not, must be freight pre-paid and accompany a return authorization (R.A.) number. The R.A. number must be clearly written on the outside of the return package. A brief description of the problem as well as the R.A. number must also be written down on a piece of paper and included in the shipping container. If the unit is under warranty, you must provide a copy of your proof of purchase invoice and the unit must be registered online at www.avanteaudio.com to receive year 3 of the 3-year warranty. Items returned without a R.A. number clearly marked on the outside of the package will be refused and returned at customer's expense. You may obtain a R.A. number by contacting customer support.

LIMITED WARRANTY (USA ONLY)

1. ADJ Products, LLC hereby warrants, to the original purchaser, AVANTE products to be free of manufacturing defects in material and workmanship for a prescribed period of up to 3-years (1,095 days) from the original purchase date. Product must be registered online at www.avanteaudio.com in order to activate year 3 of the 3-year warranty period. This warranty shall be valid only if the product is purchased within the United States of America, including possessions and territories. It is the owner's responsibility to establish the date and place of purchase by acceptable evidence at the time service is sought.
2. For warranty service you must obtain a Return Authorization number (RA#) before sending the product back; please contact ADJ Products, LLC Service Department at 800-322-6337. Send the product only to the ADJ Products, LLC factory. All shipping charges must be pre-paid. If the requested repairs or service (including parts replacement) are within the terms of this warranty, ADJ Products, LLC will pay return shipping charges only to a designated point within the United States. If the entire instrument is sent, it must be shipped in its original package. No accessories should be shipped with the product. If any accessories are shipped with the product, ADJ Products, LLC shall incur no liability whatsoever for loss of or damage to any such accessories, or for the safe return thereof.
3. This warranty is void if the serial number has been altered or removed; if the product is modified in any manner which ADJ Products, LLC concludes, after inspection, affects the reliability of the product; if the product has been repaired or serviced by anyone other than the ADJ Products, LLC factory unless prior written authorization was issued to purchaser by ADJ Products, LLC; if the product is damaged because it was not properly maintained as set forth in the instruction manual.
4. This is not a service contract, and this warranty does not include maintenance, cleaning or periodic checkup. During the period specified above, ADJ Products, LLC will replace defective parts at its expense with new or refurbished parts, and will absorb all expenses for warranty service and repair labor by reason of defects in material or workmanship. The sole responsibility of ADJ Products, LLC under this warranty shall be limited to the repair of the product, or replacement thereof, including parts, at the sole discretion of ADJ Products, LLC. All products covered by this warranty were manufactured after August 15, 2012, and bear identifying marks to that effect.
5. ADJ Products, LLC reserves the right to make changes in design and/or improvements upon its products without any obligation to include these changes in any products theretofore manufactured. No warranty, whether expressed or implied, is given or made with respect to any accessory supplied with products described above. Except to the extent prohibited by applicable law, all implied warranties made by ADJ Products, LLC in connection with this product, including warranties of merchantability or fitness, are limited in duration to the warranty period set forth above. And no warranties, whether expressed or implied, including warranties of merchantability or fitness, shall apply to this product after said period has expired. The consumer's and/or Dealer's sole remedy shall be such repair or replacement as is expressly provided above; and under no circumstances shall ADJ Products, LLC be liable for any loss or damage, direct or consequential, arising out of the use of, or inability to use, this product. This warranty is the only written warranty applicable to ADJ Products, LLC Products and supersedes all prior warranties and written descriptions of warranty terms and conditions heretofore published.
6. Warranty Registration: Please register your product online: www.avanteaudio.com. Online product registration is required in order to activate the third year of the 3-year warranty. All returned service items, whether under warranty or not, must be freight pre-paid and accompany a return authorization (R.A.) number. The R.A. number must be clearly written on the outside of the return package. A brief description of the problem as well as the R.A. number must also be written down on a piece of paper and included in the shipping container. If the unit is under warranty, you must provide a copy of your proof of purchase invoice and the unit must be registered online at www.avanteaudio.com to receive year 3 of the 3-year warranty. Items returned without a R.A. number clearly marked on the outside of the package will be refused and returned at customer's expense. You may obtain a R.A. number by contacting customer support.

SAFETY GUIDELINES

This speaker is a sophisticated piece of electronic equipment. To guarantee a smooth operation, it is important to follow all instructions and guidelines in this manual. AVANTE is not responsible for injury and/or damages resulting from the misuse of this speaker due to the disregard of the information printed in this manual. Only qualified and/or certified personnel should perform the installation of this speaker and all included and/or optional rigging accessories. Only the original included and/or optional rigging parts and accessories for this speaker should be used for proper installation. Any modifications to the speaker, included and/or optional rigging parts and accessories will void the original manufactures warranty and increase the risk of damage and/or personal injury.



PROTECTION CLASS 1 – SPEAKER MUST BE PROPERLY GROUNDED

TO REDUCE RISK OF ELECTRICAL SHOCK, DO NOT REMOVE ANY COVER.

THERE ARE NO USER SERVICEABLE PARTS INSIDE THIS SPEAKER.

DO NOT ATTEMPT ANY REPAIRS YOURSELF; DOING SO WILL VOID YOUR MANUFACTURES WARRANTY. DAMAGES RESULTING FROM MODIFICATIONS TO THIS SPEAKER AND/OR THE DISREGARD OF SAFETY INSTRUCTIONS AND GUIDELINES IN THIS MANUAL VOID THE MANUFACTURES WARRANTY AND ARE NOT SUBJECT TO ANY WARRANTY CLAIMS AND/OR REPAIRS. NEVER OPEN THIS SPEAKER WHILE IN USE! UNPLUG POWER BEFORE SERVICING SPEAKER!

KEEP FLAMMABLE MATERIALS AWAY FROM SPEAKER!



DRY LOCATIONS USE ONLY!

DO NOT EXPOSE SPEAKER TO RAIN AND/OR MOISTURE!

DO NOT SPILL WATER AND/OR LIQUIDS ON OR INTO THE SPEAKER!

This speaker is for **PROFESSIONAL USE ONLY!** Read all **INSTRUCTIONS** and follow all **WARNINGS!**

DO NOT use speaker near wet and/or damp locations. Speaker must be kept away from direct contact with liquids and must not be exposed to water/liquid dripping or splashing.

DO NOT attempt installation and/or operation without knowledge how to do so. Consult a professional sound equipment installer for proper and safe speaker installation. **ONLY** the original included, and/or optional rigging parts and accessories listed in this manual should be used for proper installation and use.

DO NOT expose any part of the speaker to open flame or smoke, or position speaker close to any flammable materials while operating. Be sure to install this speaker in an area that will allow proper ventilation. Allow approximately 6 inches (152mm) behind the speaker cabinet for proper cooling. The speaker contains an internal power amplifier that produces heat during use. Keep speaker away from heat sources such as radiators, heat registers, stoves, or other appliances (including amplifiers) that produce heat.

DO NOT operate speaker if power cord is frayed, crimped, damaged, and/or if any of the power cord connectors are damaged and do not insert into the speaker securely with ease. **NEVER** force a power cord connector into the speaker. If the power cord or any of its connectors are damaged, replace it immediately with a new one of similar power rating.

DO NOT disassemble speaker, there are NO user serviceable parts inside. Refer all servicing to qualified service personnel. Servicing is required when the speaker has been damaged in any way, such as power-supply cord or plug is damaged, liquid has been spilled and/or objects have fallen into the speaker, the speaker has been exposed to rain and/or moisture, does not operate normally, or has been dropped.

DO NOT defeat the safety purpose of the polarized or grounding-type plug. A polarized plug has two blades with one wider than the other. A grounding type plug has two blades and a third grounding prong. The wide blade or the third prong is provided for your safety. If the provided plug does not fit into your outlet, consult an electrician for replacement of the obsolete outlet.

SAFETY GUIDELINES

POWER SOURCES: This product must be connected to a power supply only of the type described in these operating instructions, or as marked on the unit. This product is Country Specific.

PROTECTIVE EARTHING TERMINAL: The speaker should be connected to a mains socket outlet with a protective earth-ground/earthing connection.

ONLY handle power cord by the plug end, never pull the plug out by tugging the wire portion of the cord.

DO NOT use solvents or glass cleaner to clean speaker. Clean only with a dry cloth.

ALWAYS disconnect speaker from main power source before performing any servicing or cleaning procedure.

CAUTION: To avoid physical damage, read the installation instructions carefully before installation.

CAUTION: Listening to speakers at high volume for extended time or within immediate proximity may damage hearing.

CAUTION: Speakers should be installed/operated by qualified and trained professionals **ONLY**.

CAUTION: Always mount speakers in a safe and stable manner.

CAUTION: Wear appropriate safety equipment during speaker installation.

CAUTION: Route power and audio cables so that they are **NOT** likely to be walked on or pinched.

CAUTION: Unplug the speaker during lightning storms and/or when unused for long periods of time.

ONLY use the original packaging materials and/or case to transport the speaker in for service.

PLEASE recycle shipping boxes and packaging whenever possible.

MAINTENANCE GUIDELINES

Regular maintenance is necessary to optimize the potential functional lifespan of the speakers.

1. Read the installation and operation instructions for correct operation of the speakers.
2. Although the speakers are rugged and designed to withstand limited impact forces when installed correctly, take care to avoid impact damage when handling or transporting speakers, especially the speaker mesh screen.
3. The speakers should be serviced by a qualified service technician when:
 - A. Objects have fallen, or liquid has been spilled into the speaker.
 - B. Been exposed to rain or water conditions.
 - C. Does not appear to operate normally or exhibits a marked change in performance.
 - D. Has fallen and/or been subjected to extreme handling.
4. Check each speaker for loose screws and/or other fasteners.
5. If the speaker installation is fixed or displayed for a lengthy time, regularly inspect all rigging and installation equipment, and replace or repair it as necessary, and during long periods of non-use, disconnect the main power to the unit.
6. If while conducting an electrical test a circuit shorts, a breaker-switch trips, wires burn, and or any other abnormality appears, discontinue testing, and troubleshoot units to find the problem before continuing with any testing or operation.
7. The speakers are designed for dry locations use only.
8. When not in use, store speakers in a dry, well ventilated storage location.

OVERVIEW

INCLUDED ITEMS

- (1X) Active subwoofer with built in mixer (8" driver)
- (1X) Speaker Column (speaker array with (6x) 2.75" drivers)
- (1X) Riser/Support Column
- (1X) IEC Power Cable
- (1X) Travel Bag



OVERVIEW

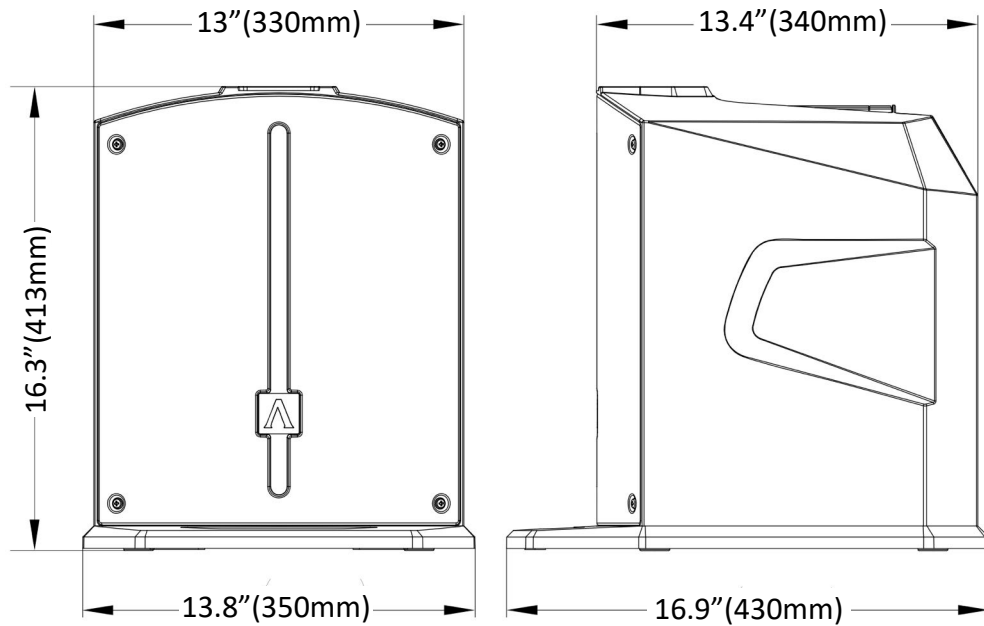
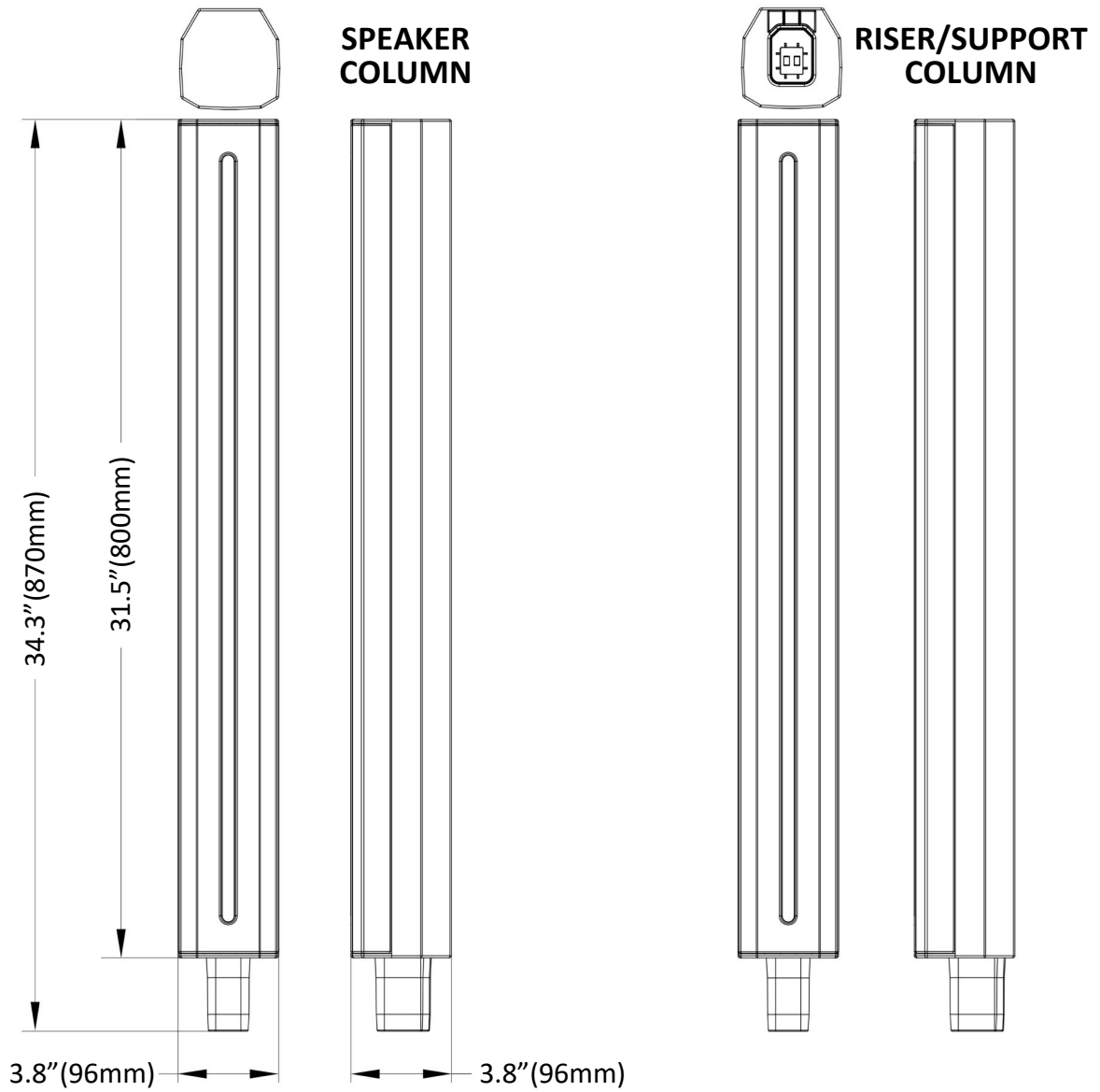

SETUP

- Position the AS8 in the desired location and ensure that the speaker is stable.
- Make sure the POWER switch is OFF.
- Make certain INPUT GAIN 1, INPUT GAIN 2, and MASTER VOLUME are down.
- Set EQUALIZER knobs to center (12 o'clock).
- Insert the Riser/Support Column into the sub.
- Insert the Speaker Column into the Riser/Support Column.

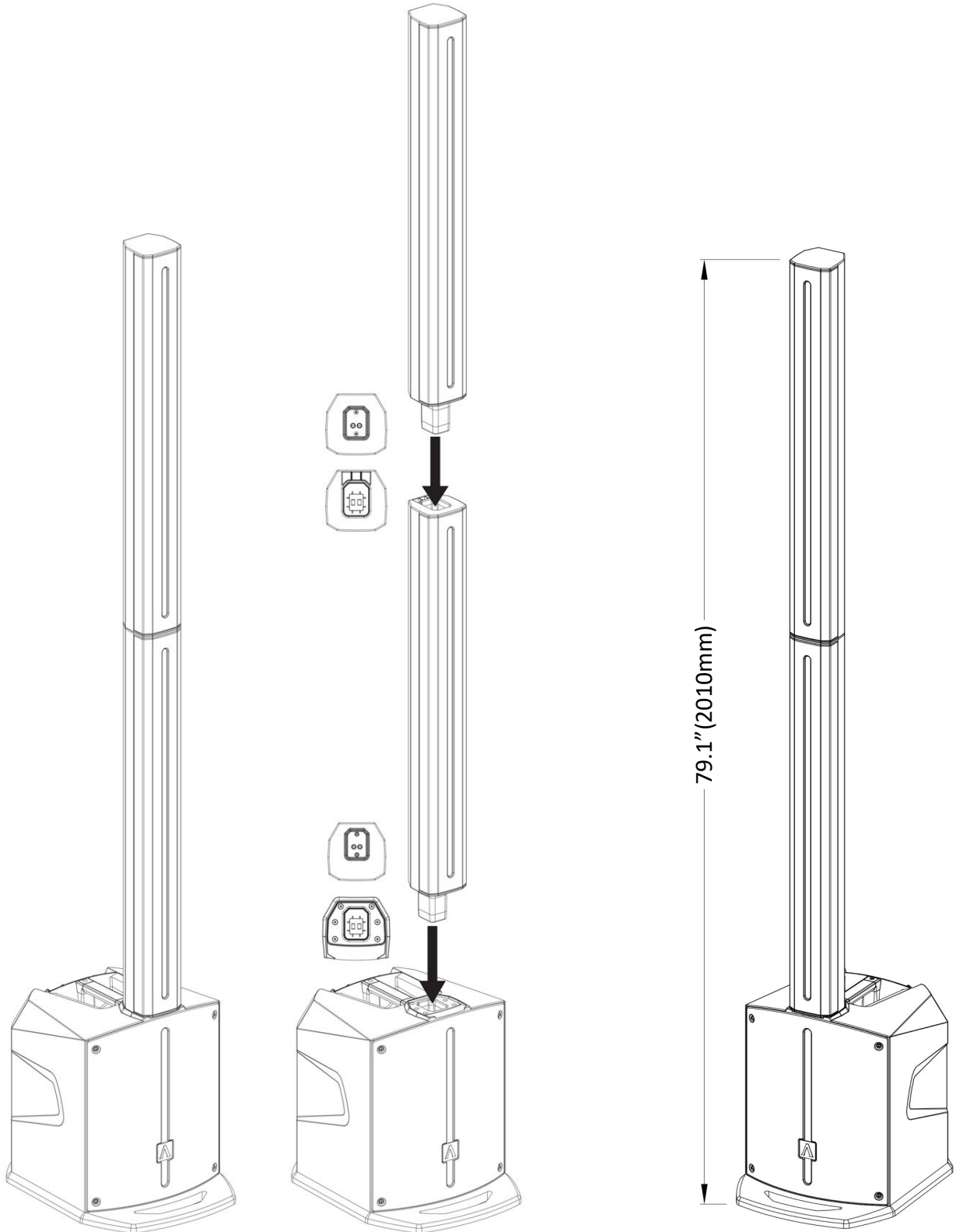

CONNECTIONS & CONTROLS

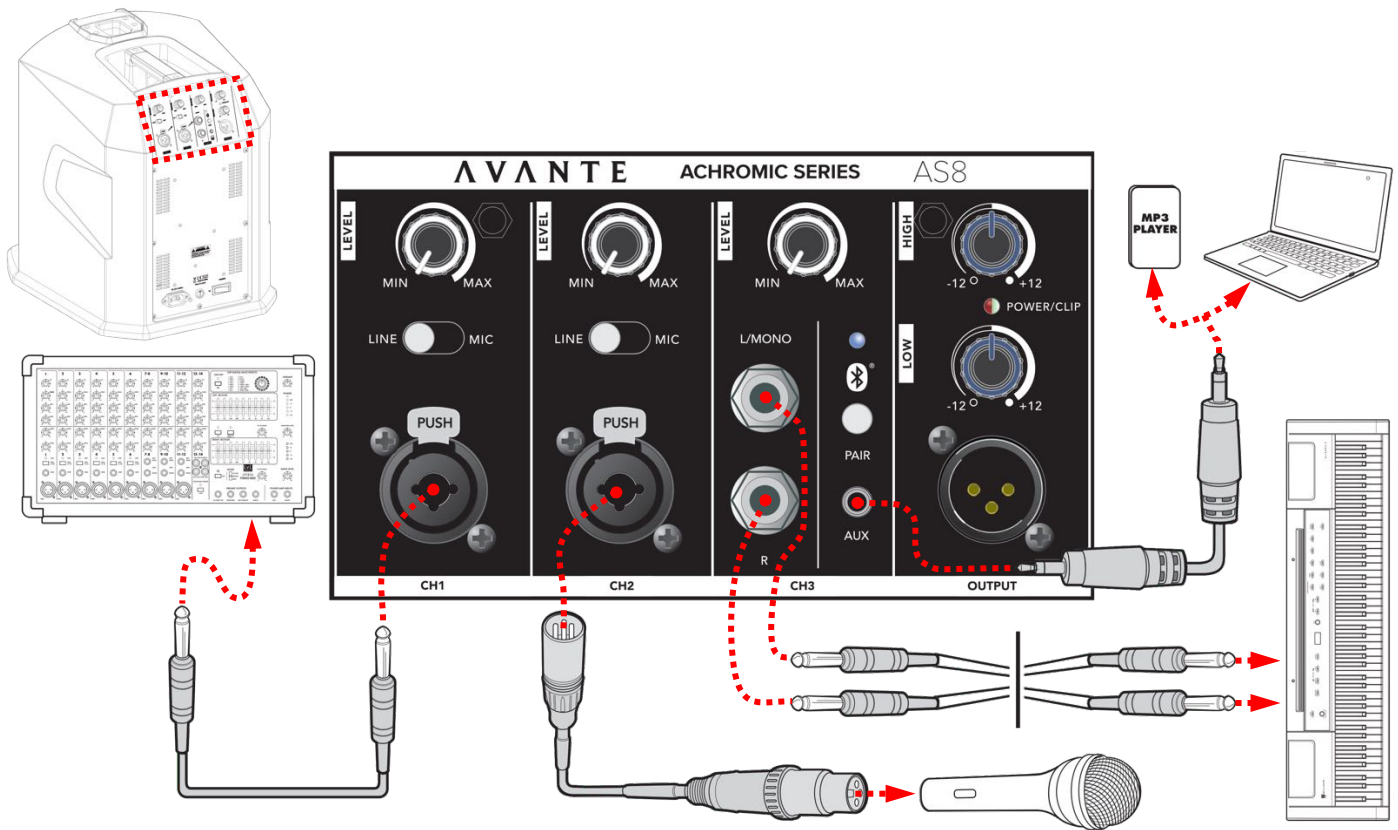

MAKING CONNECTIONS

- Plug connection to INPUT 1 (CH1) – check that the MIC/LINE switch matches the source (Mic for microphones and instruments, Line for mixers, keyboards, or instruments with active pickups).
- Plug connection to INPUT 2 (CH2) – this works like INPUT 1.
- Plug connection to INPUT 3 (CH3) – STEREO jack is great for your phone, mobile audio device or computer. -10dB LINE jacks are great for keyboard, drum machine or other line level devices. See BLUETOOTH® CONTROLS section to use a wireless device as the source for INPUT 3 (see page #).

POWERING UP

- Turn on the power to any devices plugged into Input 1 (CH1) , Input 2 (CH2), or Aux Input (CH3) and ensure their output volumes are turned up. (Generally, you'll get the best sound by turning their output volume to maximum, then making any volume adjustment via the input gain controls of the AS8s).
- Power ON the AS8.
- Slowly turn INPUT 1 (CH1) GAIN, INPUT 2 (CH2) GAIN, and INPUT 3 (CH3) GAIN to the desired levels.

POWER/CLIP LED AND PROPER LEVELS

- This LED on the AS8 should normally be green when its AC power cord is connected to an electrical outlet, and the Power Switch is turned on.
- If this LED is constantly turning red, one of the input signals is too high.
- Turn down each input gain volume knob in turn to find which is distorting, and set that knob to clipping.

FLOOR MONITOR APPLICATIONS

- Turn the LOW Equalizer knob down slightly to reduce unwanted rumble and low-frequency build-up. This will reduce feedback and make vocals clearer.
- Power ON the AS8. Slowly turn INPUT 1 GAIN, INPUT 2 GAIN, and INPUT 3 GAIN to the desired levels.

LINKING MULTIPLE SPEAKERS

- If linking multiple speakers, connect all input sources to the first AS8 to the LINE IN connection of the next AS8, and continue the daisy chain to the last AS8. (This is common where multiple monitor mixers share the same feed from the mixing board.)
- To avoid “pops” when turning power on/off, the last AS8 should be powered on last, and powered off first.

CONNECTIONS & CONTROLS

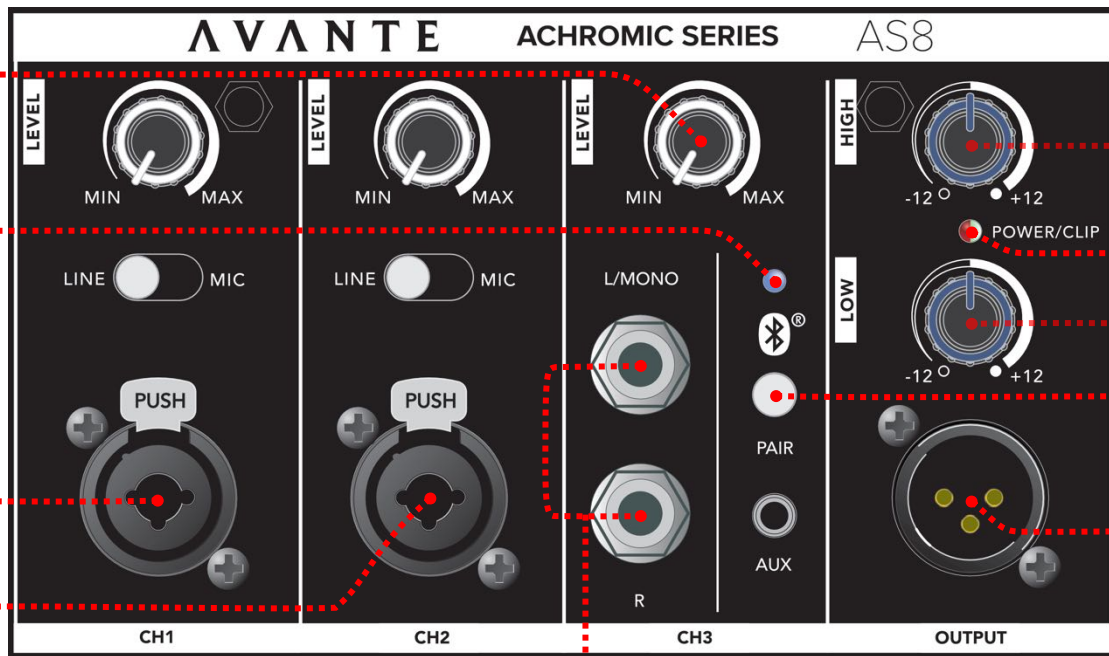

1. **CHANNEL 1:** This input accepts balanced XLR plugs, and balanced/unbalanced TRS (tip/ring/sleeve) 1/4" plugs. Set the LINE/MIC switch to match the type of device you've connected to prevent distortion. When using an unbalanced 1/4" instrument jack, start with the button in LINE setting. Then, if the gain is too low, turn the volume down, select MIC, and slowly raise the volume.
2. **CHANNEL 2:** This input accepts balanced XLR plugs, and balanced/unbalanced TRS (tip/ring/sleeve) 1/4" plugs. Set the GTR/MIC switch to match the type of device you've connected to prevent distortion. When using an unbalanced 1/4" instrument jack, start with the button in GTR setting. Then, if the gain is too low, turn the volume down, select MIC, and slowly raise the volume.
3. **CHANNEL 3 LEVEL KNOB:** This knob sets the volume for Channel 3.
4. **CHANNEL 3 AUX JACKS:** The small 1/8" jack is for connecting a portable audio device like a phone, a computer, MP3, or CD player. The L (left) and R (right) jacks can be used for -10dB line level devices like keyboards or drum machines. For best results, do not use the 1/8" and L/R jacks simultaneously.
5. **CHANNEL 3 BT:** Bluetooth® (BT).
6. **CHANNEL 3 BLUETOOTH® CONTROLS:** To use a Bluetooth-enabled device like your phone or computer as the source for Input 3, you must first "pair" it with your AS8.
 - Power on your AS8 and enable Bluetooth on your source device (phone, computer, or other mobile device).
 - From your source device, display its list of discovered Bluetooth devices and look for "AVANTE AS8" there. If you don't see it, try scrolling the list to make sure it's not hidden off-screen. If it's not listed, push and release the PAIR/play/pause button on your AS8.
 - Once you do see "AVANTE AS8" on the list, select it, and your source device and your AS8 will pair, while the AS8 plays a chime and lights the Bluetooth LED blue.
 - Play audio from your Bluetooth source device, and you'll now hear it via INPUT 3 of your AS8 as the Bluetooth LED slowly flashes.
 - Pressing the PAIR/play/pause button will now remotely control the play/pause action of your device, with the Bluetooth LED flashing during play, and solid while paused.
 - To "disconnect" your Bluetooth device Input 3, press and hold the PAIR/play/pause button. The LED will turn off and you will hear a chime.
 - When you power on your AS8, it will look for any previously paired device, and pair with it automatically if available.
7. **LOW AND HIGH EQ KNOBS:** The LOW knob will provide +/- 12dB of boost or cut below 100Hz. Turn LOW up to add bass or warmth to the speaker. Turn LOW down to remove rumble and noise when the program material does not contain low frequencies, or when using the speaker as a floor monitor. The HIGH knob will provide +/-12dB of boost, or cut above 10kHz. Turn HIGH up to add clarity and definition to vocals, acoustic instruments, or backing tracks. Turn HIGH down to reduce hiss or feedback.
8. **POWER/CLIP LED:** The green LED on the AS8 indicates that AC power cord is connected to an electrical outlet, and the Power Switch is turned on. If you see the red LED while audio is playing into the speaker, this indicates that the speaker is being overdriven, and the limiter is engaged. If the CLIP LED is constantly lit, first reduce the Gain on the Input channels.
9. **LINE OUT 0.0dB:** The LINE OUT provides a 0.0dB level signal and is used to link multiple AS8 units together using the same audio signal. Connect the LINE OUT of the first AS8 to a Line Input of the next AS8 in the signal path.

CONNECTIONS & CONTROLS

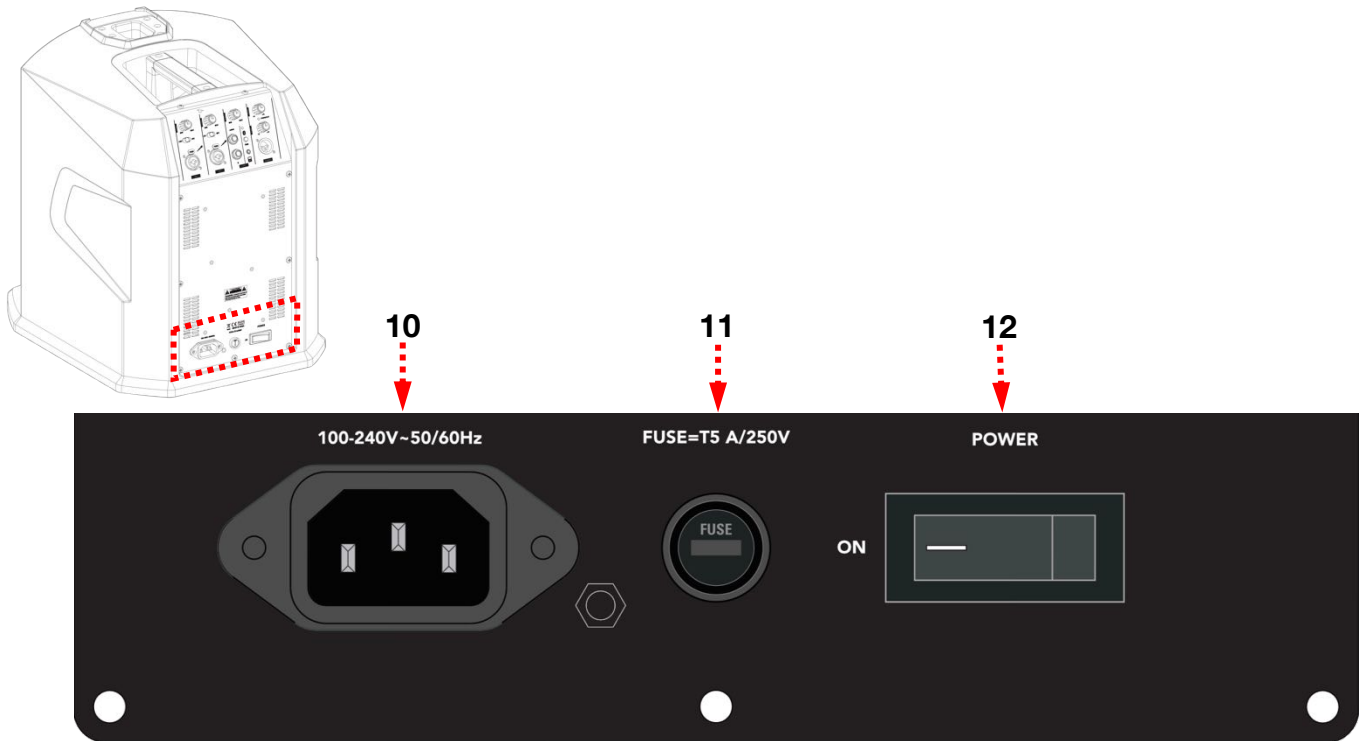

10. **IEC POWER INPUT:** The IEC AC cable plug inserts into this jack.

11. **FUSE:** The power must be turned off and device disconnected from mains before replacing the fuse. Only use a fuse with the same rating and power, which is specified on rear panel.

12. **POWER:** Turns the AS8 power ON or OFF.

INSTALLATION



**DO NOT INSTALL SPEAKERS IF YOU ARE NOT QUALIFIED TO DO SO!
INSTALLATION BY QUALIFIED TECHNICIANS ONLY!**



INSTALLATIONS SHOULD BE CHECKED BY A QUALIFIED PERSON ONCE A YEAR!



FLAMMABLE MATERIAL WARNING

Keep speaker a minimum of 5.0 feet (1.5m) away from flammable materials and/or pyrotechnics.



ELECTRICAL CONNECTIONS

A qualified electrician should complete all electrical connections and/or installations.



USE CAUTION WHEN POWER LINKING MULTIPLE SPEAKERS AS THE POWER CONSUMPTION OF OTHER SPEAKER MODELS MAY EXCEED THE MAX POWER OUTPUT ON THIS SPEAKER. CHECK SILK SCREEN ON SPEAKER FOR MAX AMPS.

WARNING! The safety and suitability of any lifting equipment, installation location/platform, anchoring/rigging/mounting method, hardware, and electrical installation is the sole responsibility of the installer.

Install speaker(s), all speaker accessories, and all anchoring/rigging/mounting hardware following all local, national, and country commercial, electrical, and construction codes and regulations.

Install speakers(s) in areas outside walking paths, seating areas, or away from areas where unauthorized personnel might reach the speaker(s) by hand.

Take all appropriate precautions and safety measures when placing equipment in potentially dangerous locations, especially where public safety is a concern.

FREQUENCY CHART

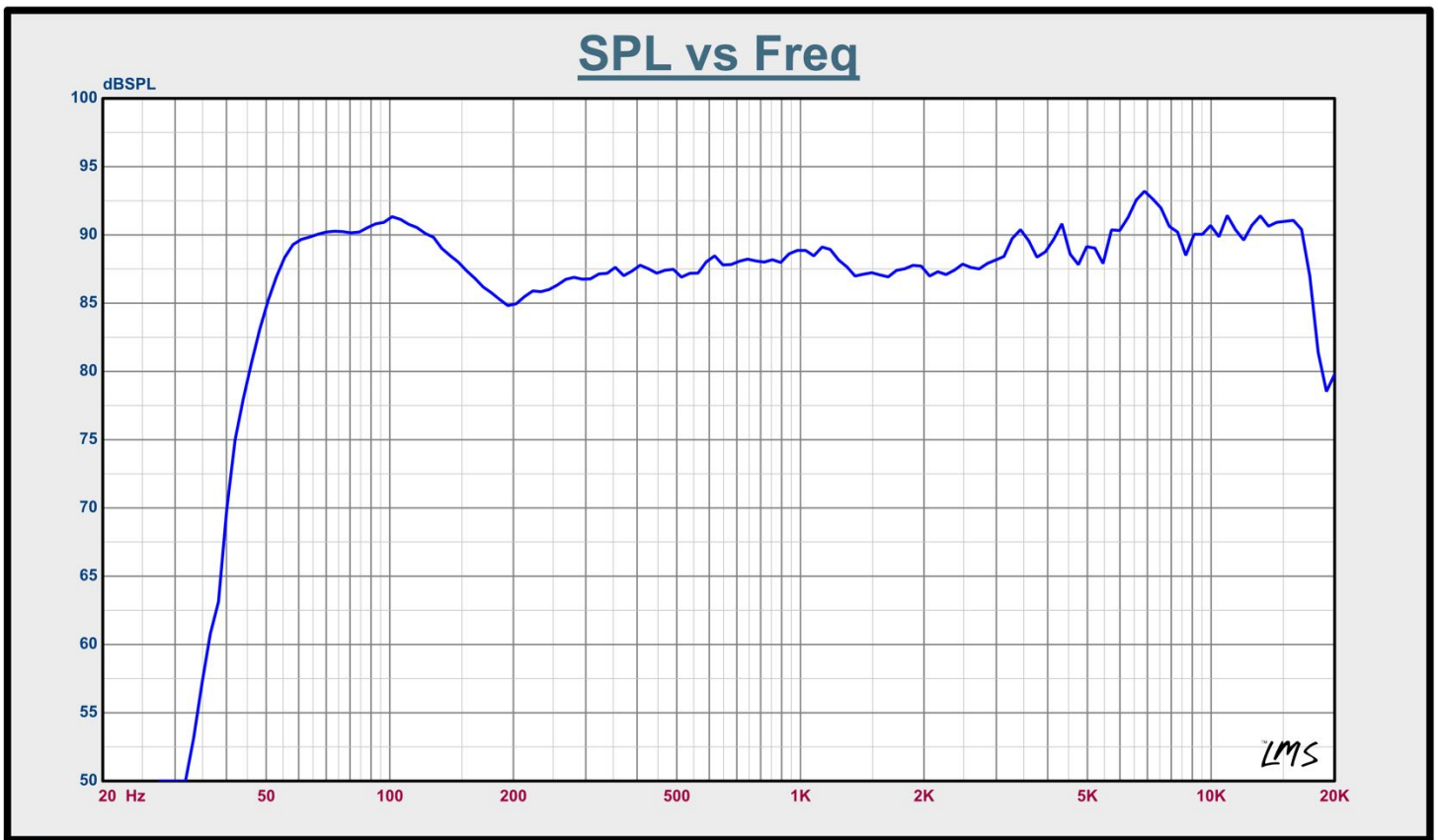

TROUBLESHOOTING

Mixer and Amplifier Will Not Turn On

Is the included power cord correctly connected to a power outlet? (Is it plugged in?)

Amplifier Turns Off Suddenly

Are any vents of the mixer blocked? Since inadequate venting will cause the product to overheat, turn off the mixer and uncover the vents to allow the product and its internal amplifier to cool. After a few minutes, the product should reset itself and can return to normal playback.

Is the POWER/CLIP LED flashing continuously?

If the POWER/CLIP LED is flashing, the amplifier is being used beyond its design capabilities. Turn off and on and resume playback.

No Sound From the Speaker(s)

Are external instruments and/or microphones correctly connected to inputs? Are those sources powered on, and is all cabling functional? Are the input gain controls of all active inputs set appropriately? If using Bluetooth®, is the AUX/BLUETOOTH switch set to Bluetooth, have your source device and AS8 successfully paired, is your source device still active (not asleep or out of battery power), and audio with its output level control set appropriately?

Distortion/Noise in the Audio Signal, Low Output Level

You will generally get the lowest noise (hiss) by setting source device output to max., and then making any reductions of the volume via the AS8 input gain knobs. Are the output levels of any source devices set appropriately? Are the INPUT GAIN controls for all inputs set to appropriate levels? Are the MIC/LINE switches of each input set appropriately? Are both the STEREO jack and the -10dB LINE IN jacks on INPUT 3 being used (connected) at the same time? If the POWER/CLIP LED is lighting, you should try adjusting each INPUT GAIN knob in turn to find which is the source of clipping.

Sound Level is too loud During Voice Announcements

Is the INPUT GAIN level for the mic input set too high? Are the levels for your other inputs set too low, either on the source device(s), or at their INPUT GAIN controls.

What is the Bluetooth® audio range of the AS8 system?

Effective line-of-sight range is up to 50 feet. The wireless performance of the AS8 is significantly affected by walls or metal, interference by WiFi or other wireless devices.

TECHNICAL SPECIFICATIONS

Amplifier	
Inputs	2xXLR/TRS combo jacks, Stereo RCA & Stereo 1/8" inputs, Bluetooth®
Outputs	XLR balanced line output
Power output	RMS 250W RMS, 800W peak
Volume	Input Gain control per channel
EQ	Main out 2 band shelving EQ
LEDs	Power/Clip indicator
Power Input	100-240V~50/60Hz switchable 250W
Amplifier	Class D amplifier with switching power design
Subwoofer	Active vented subwoofer
Frequency Response	55-200Hz
Max output SPL	116dB (at max. amp output)
Impedance	4 Ohm
Driver	8" subwoofer, 1.5" vc 28Oz
Cabinet	PP plastic
Grill	1.0mm steel
Satellite	Passive full-range speaker
Frequency response	180-20kHz
Max. output SPL	120dB
Impedance	4ohms
Driver	6x2.75" full range line array
Cabinet	ABS plastic
Grill	1.0mm steel
MEAS/G.W.	24.5x14x92.5CM/1PC/6.45KG (SAT) 51x44x48CM/1PC/13.3KG (SUB)
Listings	FCC, CE, & ETL

Specifications subject to change without any prior written notice.



COMPONENTS & ACCESSORIES

Model # (SKU)	Description
WM219	WM-219 Wireless Microphone System
WM419	WM-419 Wireless Microphone System
VPS564	VPS-80 Microphone
VPS916	VPS-60 Microphone
VPS205	VPS-20 Microphone
PWR571	Pow-R Bar65

(Intentionally Blank)

